

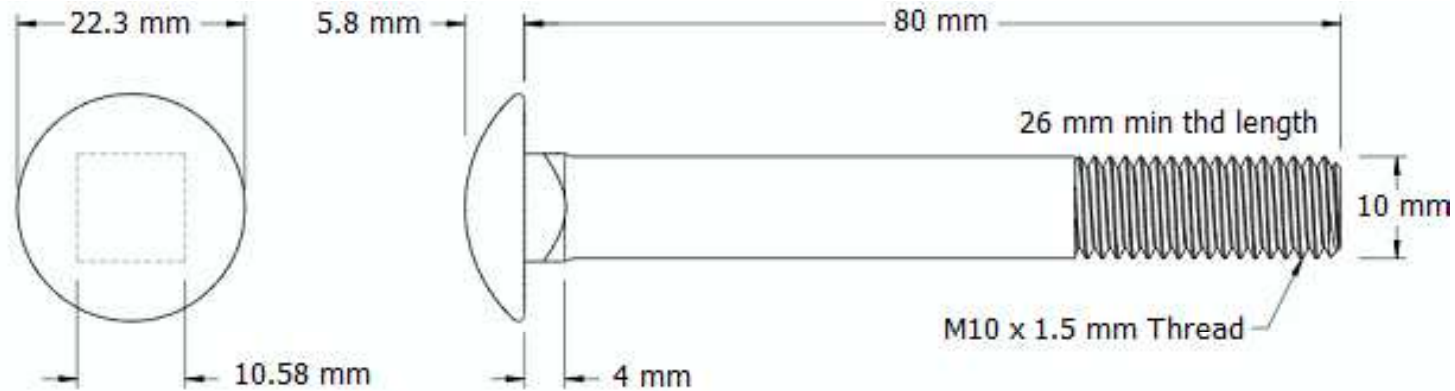

This drawing and the information contained herein are the confidential and proprietary property of Global Supply LLC



**NOTES:**

1. INTERPRET DRAWINGS PER DIN 603 STANDARD.
2. DIMENSIONS AND TOLERANCES PER ANSE/ASME 18.5
3. ROHS AND REACH COMPLIANT

<b>DRAWING SCALE:</b>		<b>MATERIAL:</b>		<b>DESCRIPTION:</b>	
<b>METRIC</b>		<b>STAINLESS STEEL</b>		<b>M10 X 80 MM SQUARE NECK, CARRIAGE BOLT</b>	
<b>TOLERANCES:</b> <i>Unless specified otherwise, all dimensions are in millimeters</i>		<b>FINISH:</b>		<b>PART NUMBER:</b>	
x.xxx +/- 0.100 x.xx +/- 0.100 x.x +/- 0.100		<b>PASSIVATE</b>		<b>.100C800BCRSP</b>	
<b>DRAWN BY:</b>	<b>L CLARY</b>		<b>FCSM No.</b> <b>67012</b>		 <b>Global Supply LLC</b> WORLDWIDE SUPPLIER OF ELECTRONIC HARDWARE, FASTENERS & COMPONENTS 500 Division Street, Campbell, CA 95008-6906 Tel: 408 960 0370 Fax: 408 960 0375 Web: www.globalsupply.com
<b>REV:</b>	<b>APPROVAL</b>	<b>DATE:</b>			
<b>INITIAL REV</b>	LJA	Sep 17, 2018			
			<b>ECCN</b>		
			EAR99 = NLR (No License Required)		