

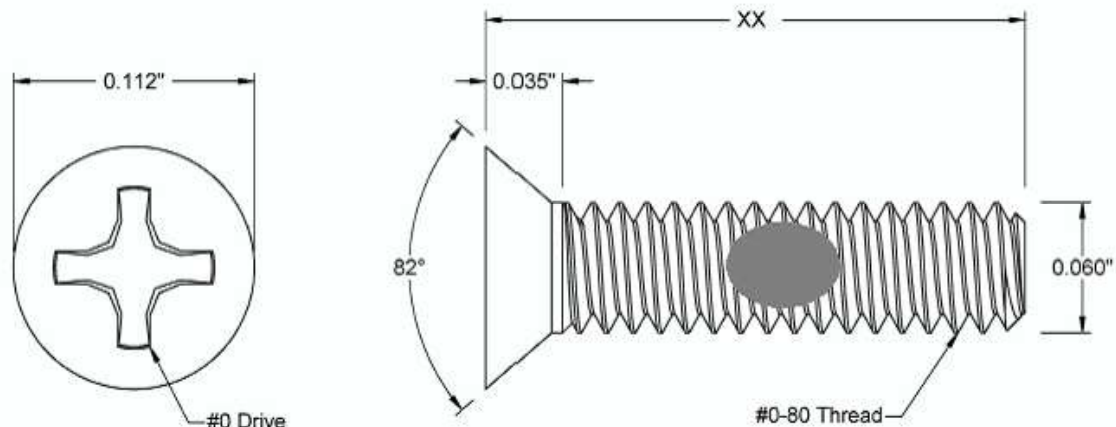

This drawing and the information contained herein are the confidential and proprietary property of Global Supply LLC



PART NUMBER	LENGTH
OF6MP8SP/SPA	3/32
OF8MP8SP/SPA	1/8
OF10MP8SP/SPA	5/32
OF12MP8SP/SPA	3/16
OF16MP8SP/SPA	1/4
OF20MP8SP/SPA	5/16
OF24MP8SP/SPA	3/8
OF32MP8SP/SPA	1/2
OF40MP8SP/SPA	5/8
OF48MP8SP/SPA	3/4
OF56MP8SP/SPA	7/8
OF64MP8SP/SPA	1

NOTES:
 1. INTERPRET DRAWINGS PER ASME Y14.5M-1994 STANDARD.
 2. DIMENSIONS & TOLERANCES PER ANSI/ASME B18.6.3
 3. ROHS AND REACH COMPLIANT

DRAWING SCALE:		MATERIAL:	DESCRIPTION:
STANDARD		STAINLESS STEEL	#0-80 PHILLIPS FLAT 82° HEAD MACHINE SCREW, PATCHED
TOLERANCES: <i>Unless specified otherwise, all dimensions are in inches</i>	x.xxx +/- 0.005 x.xx +/- 0.010 x.x +/- 0.010	FINISH:	PART NUMBER:
		PASSIVATE	OFXXMP8SP/SPA
DRAWN BY:	L.CLARY		 Global Supply LLC WORLDWIDE SUPPLIER OF ELECTRONIC HARDWARE, FASTENERS & COMPONENTS <small>500 Division Street, Campbell, CA 95008-6906 Tel: 408 960 0370 Fax: 408 960 0375 Web: www.globalsupply.com</small>
REV:	APPROVAL	DATE:	
INITIAL RELEASE	LJA	Jul 16, 2018	
		FSCM No. 67012	
		ECCN	
		EAR99 = NLR (No License Required)	