

This drawing and the information contained herein are the confidential and proprietary property of Global Supply LLC

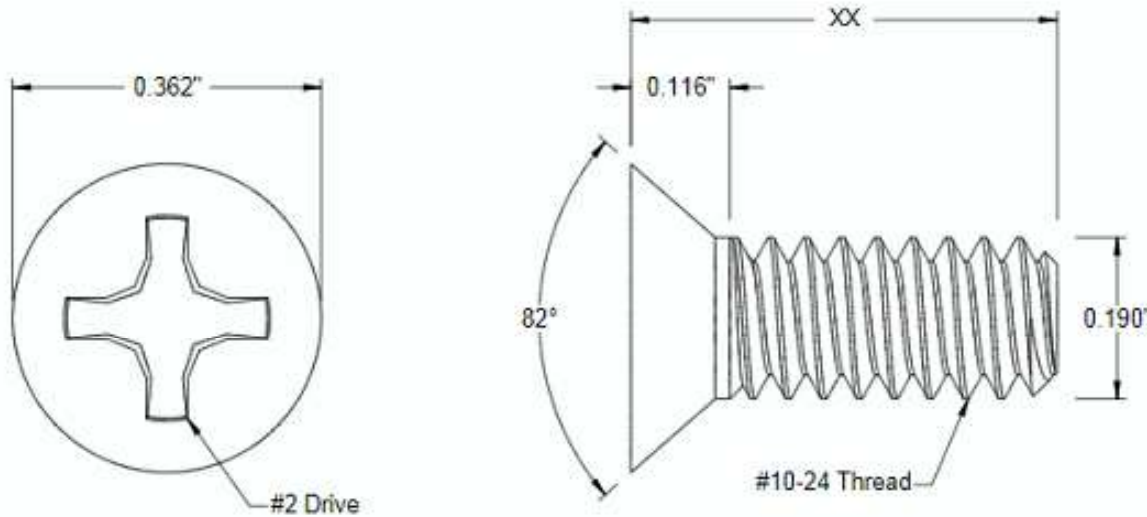

PART NUMBER	LENGTH
10C8MP82Z	1/8
10C12MP82Z	3/16
10C16MP82Z	1/4
10C20MP82Z	5/16
10C24MP82Z	3/8
10C28MP82Z	7/16
10C32MP82Z	1/2
10C40MP82Z	5/8
10C44MP82Z	11/16
10C48MP82Z	3/4
10C56MP82Z	7/8
10C64MP82Z	1



NOTES:
 1. INTERPRET DRAWINGS PER ASME Y14.5M-1994 STANDARD.
 2. DIMENSIONS & TOLERANCES PER ANSI/ASME B18.6.3.

DRAWING SCALE:		MATERIAL:	DESCRIPTION:
STANDARD		STEEL	10-24 PHILLIPS FLAT HEAD 82° MACHINE SCREW
TOLERANCES: <i>Unless specified otherwise, all dimensions are in inches</i>	x.xxx +/- 0.005 x.xx +/- 0.010 x.x +/- 0.010	FINISH:	PART NUMBER:
		ZINC I	10CXXMP82Z
DRAWN BY:	L CLARY	FSCM No.	 Global Supply LLC WORLDWIDE SUPPLIER OF ELECTRONIC HARDWARE, FASTENERS & COMPONENTS <small>500 Division Street, Campbell, CA 95008-6906 Tel: 408 960 0370 Fax: 408 960 0375 Web: www.globalsupply.com</small>
REV:	APPROVAL	DATE:	
INITIAL RELEASE	LJA	Sep 5, 2018	
		ECCN	
		EAR99 = NLR (No License Required)	