

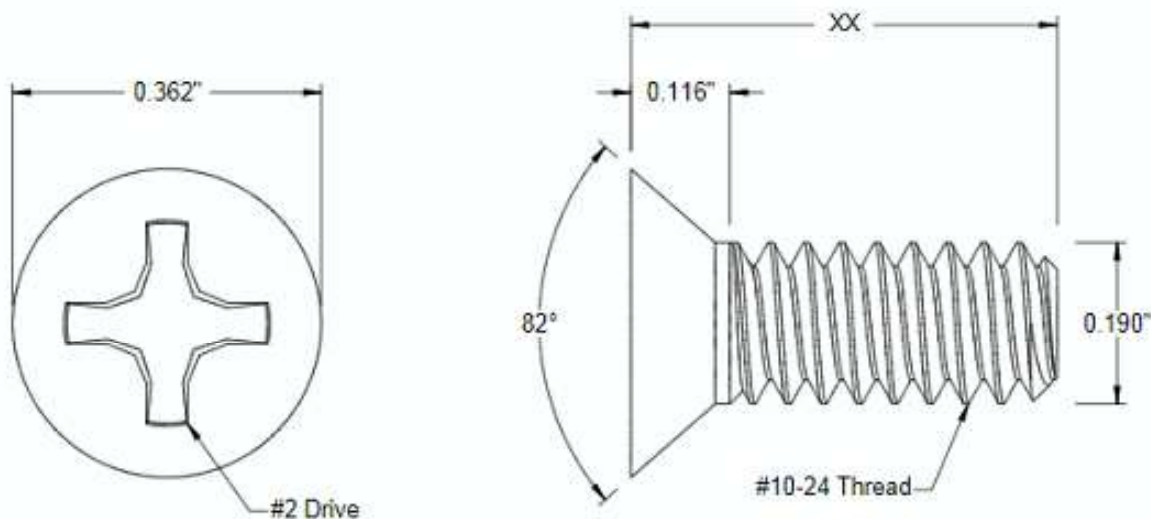

This drawing and the information contained herein are the confidential and proprietary property of Global Supply LLC



PART NUMBER	LENGTH
10C8MP8SP	1/8
10C12MP8SP	3/16
10C16MP8SP	1/4
10C20MP8SP	5/16
10C24MP8SP	3/8
10C28MP8SP	7/16
10C32MP8SP	1/2
10C40MP8SP	5/8
10C44MP8SP	11/16
10C48MP8SP	3/4
10C56MP8SP	7/8
10C64MP8SP	1



NOTES:
 1. INTERPRET DRAWINGS PER ASME Y14.5M-1994 STANDARD.
 2. DIMENSIONS & TOLERANCES PER ANSI/ASME B18.6.3.
 3. ROHS AND REACH COMPLIANT

DRAWING SCALE:		MATERIAL:	DESCRIPTION:
STANDARD		STAINLESS STEEL	10-24 PHILLIPS FLAT HEAD 82° MACHINE SCREW
TOLERANCES: <i>Unless specified otherwise, all dimensions are in inches</i>	x.xxx +/- 0.005 x.xx +/- 0.010 x.x +/- 0.010	FINISH:	PART NUMBER:
		PASSIVATE	10CXXMP8SP
DRAWN BY:	L CLARY		 Global Supply LLC WORLDWIDE SUPPLIER OF ELECTRONIC HARDWARE, FASTENERS & COMPONENTS <small>500 Division Street, Campbell, CA 95008-6906 Tel: 408 960 0370 Fax: 408 960 0375 Web: www.globalsupply.com</small>
REV:	APPROVAL	DATE:	
INITIAL RELEASE	LJA	Jul 16, 2018	
		FSCM No. 67012	
		ECCN	
		EAR99 = NLR (No License Required)	