

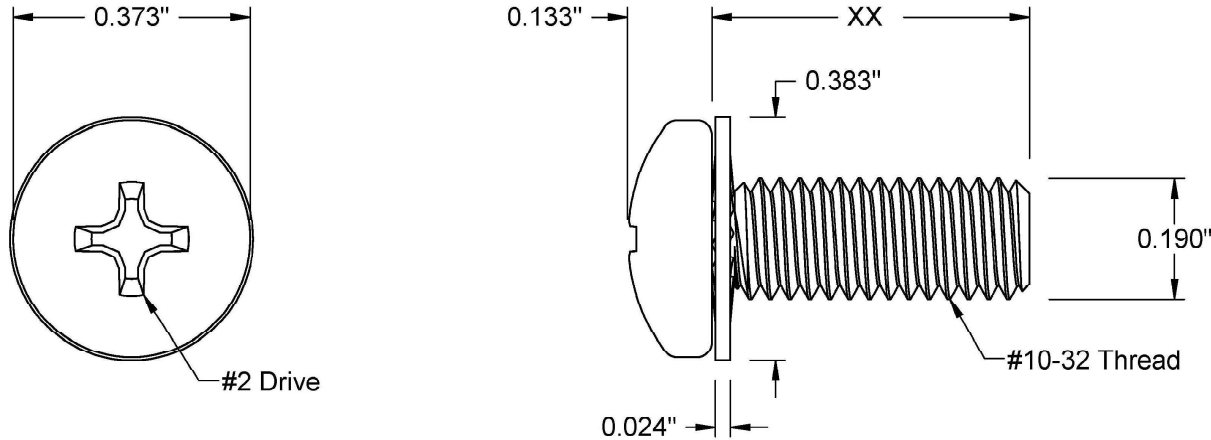

This drawing and the information contained herein are the confidential and proprietary property of Global Supply LLC



PART NUMBER	LENGTH
10F8MPP23/SIN	1/8
10F12MPP23/SIN	3/16
10F16MPP23/SIN	1/4
10F20MPP23/SIN	5/16
10F24MPP23/SIN	3/8
10F28MPP23/SIN	7/16
10F32MPP23/SIN	1/2
10F40MPP23/SIN	5/8
10F48MPP23/SIN	3/4
10F56MPP23/SIN	7/8
10F64MPP23/SIN	1
10F80MPP23/SIN	1 1/4
10F96MPP23/SIN	1 1/2

NOTES:
 1. INTERPRET DRAWINGS PER ASME Y14.5M-1994 STANDARD.
 2. DIMENSIONS & TOLERANCES PER ANSI/ASME B18.6.3
 3. ROHS AND REACH COMPLIANT

DRAWING SCALE: STANDARD		MATERIAL: STEEL	DESCRIPTION: #10-32 PAN PHILLIPS MACHINE SCREW, SEMS INTERNAL
TOLERANCES: <i>Unless specified otherwise, all dimensions are in inches</i>	x.xxx +/- 0.005 x.xx +/- 0.010 x.x +/- 0.010	FINISH: ZINC CLEAR RoHS	PART NUMBER: 10FXXMPP23/SIN
DRAWN BY: L.CLARY	FSCM No. 67012		 Global Supply LLC WORLDWIDE SUPPLIER OF ELECTRONIC HARDWARE, FASTENERS & COMPONENTS <small>500 Division Street, Campbell, CA 95008-6906 Tel: 408 960 0370 Fax: 408 960 0375 Web: www.globalsupply.com</small>
REV:	APPROVAL	DATE:	
INITIAL RELEASE	LJA	Mar 16, 2018	
		ECCN EAR99 = NLR (No License Required)	