

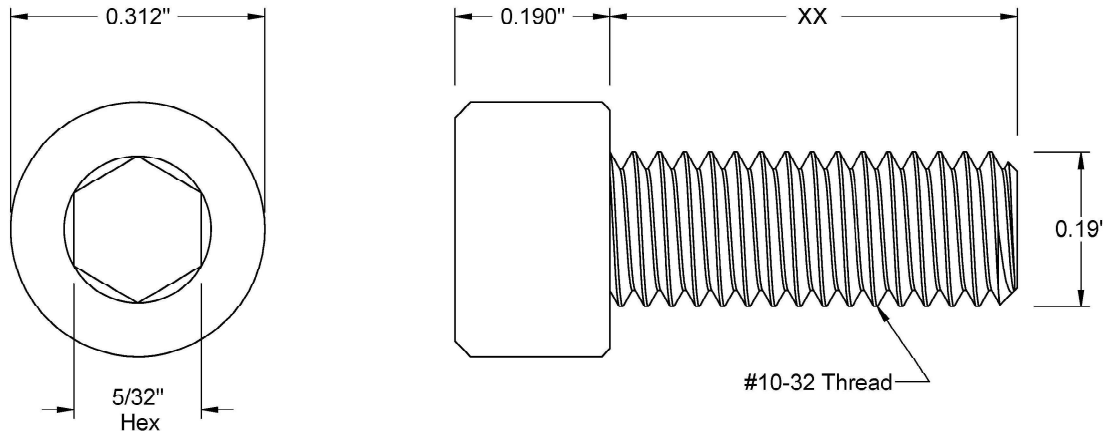

This drawing and the information contained herein are the confidential and proprietary property of Global Supply LLC



PART NUMBER	LENGTH
10F8SCSHO	1/8
10F16SCSHO	1/4
10F24SCSHO	3/8
10F28SCSHO	7/16
10F32SCSHO	1/2
10F40SCSHO	5/8
10F48SCSHO	3/4
10F56SCSHO	7/8
10F64SCSHO	1
10F80SCSHO	1 1/4

NOTES:  
 1. INTERPRET DRAWINGS PER ASME Y14.5M-1994 STANDARD.  
 2. DIMENSIONS & TOLERANCES PER ANSI/ASME B18.3  
 3. ROHS AND REACH COMPLIANT

<b>DRAWING SCALE:</b>		<b>MATERIAL:</b>	<b>DESCRIPTION:</b>
<b>STANDARD</b>		<b>ALLOY STEEL</b>	<b>#10-32 SOCKET CAP MACHINE SCREW</b>
<b>TOLERANCES:</b> <i>Unless specified otherwise, all dimensions are in inches</i>	<b>x.xxx +/- 0.005</b> <b>x.xx +/- 0.010</b> <b>x.x +/- 0.010</b>	<b>FINISH:</b>	<b>PART NUMBER:</b>
		<b>BLACK OXIDE</b>	<b>10FXXSCSHO</b>
<b>DRAWN BY:</b>	L.CLARY		 <b>Global Supply LLC</b> WORLDWIDE SUPPLIER OF ELECTRONIC HARDWARE, FASTENERS & COMPONENTS <small>500 Division Street, Campbell, CA 95008-6906          Tel: 408 960 0370 Fax: 408 960 0375 Web: www.globalsupply.com</small>
	FSCM No.		
<b>REV:</b>	<b>APPROVAL</b>	<b>DATE:</b>	
INITIAL RELEASE	LJA	Nov 2, 2009	
A	LJA	Sep 26, 2014	
B	LJA	May 2, 2018	
		ECCN	
		EAR99 = NLR (No License Required)	