

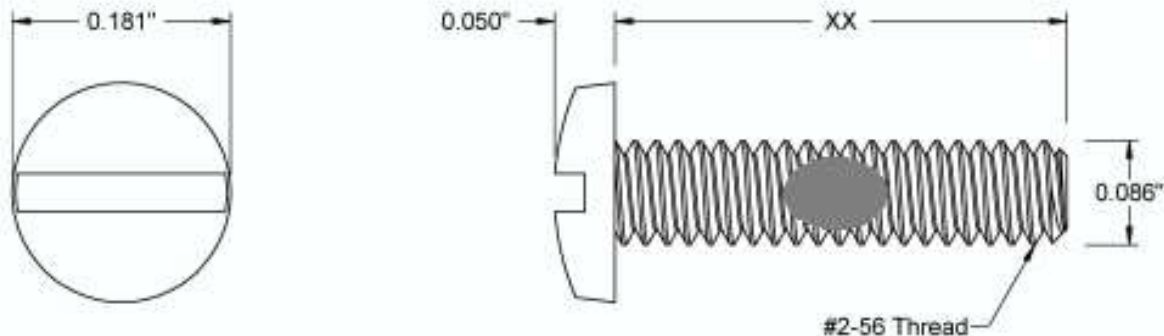

This drawing and the information contained herein are the confidential and proprietary property of Global Supply LLC



PART NUMBER	LENGTH
2C8MIBSP/SPA	1/8
2C12MIBSP/SPA	3/16
2C16MIBSP/SPA	1/4
2C24MIBSP/SPA	3/8
2C28MIBSP/SPA	7/16
2C32MIBSP/SPA	1/2
2C40MIBSP/SPA	5/8
2C48MIBSP/SPA	3/4
2C56MIBSP/SPA	7/8
2C64MIBSP/SPA	1

NOTES:
 1. INTERPRET DRAWINGS PER ASME Y14.5M-1994 STANDARD.
 2. DIMENSIONS & TOLERANCES PER ANSI/ASME B18.6.3
 3. ROHS AND REACH COMPLIANT

DRAWING SCALE:		MATERIAL:		DESCRIPTION:							
STANDARD		STAINLESS STEEL		#2-56 BINDING SLOT HEAD MACHINE SCREW, PATCHED							
TOLERANCES: <i>Unless specified otherwise, all dimensions are in inches</i>		FINISH:		PART NUMBER:							
<table border="0"> <tr> <td>x.xxx</td> <td>+/- 0.005</td> </tr> <tr> <td>x.xx</td> <td>+/- 0.010</td> </tr> <tr> <td>x.x</td> <td>+/- 0.010</td> </tr> </table>		x.xxx	+/- 0.005	x.xx	+/- 0.010	x.x	+/- 0.010	PASSIVATE		2CXXMIBSP/SPA	
x.xxx	+/- 0.005										
x.xx	+/- 0.010										
x.x	+/- 0.010										
DRAWN BY:	L.CLARY		FSCM No.		 <p>Global Supply LLC WORLDWIDE SUPPLIER OF ELECTRONIC HARDWARE, FASTENERS & COMPONENTS <small>500 Division Street, Campbell, CA 95008-6906 Tel: 408 960 0370 Fax: 408 960 0375 Web: www.globalsupply.com</small></p>						
REV:	APPROVAL	DATE:	67012								
INITIAL RELEASE	LJA	Jul 10, 2018	ECCN								
			EAR99 = NLR (No License Required)								