

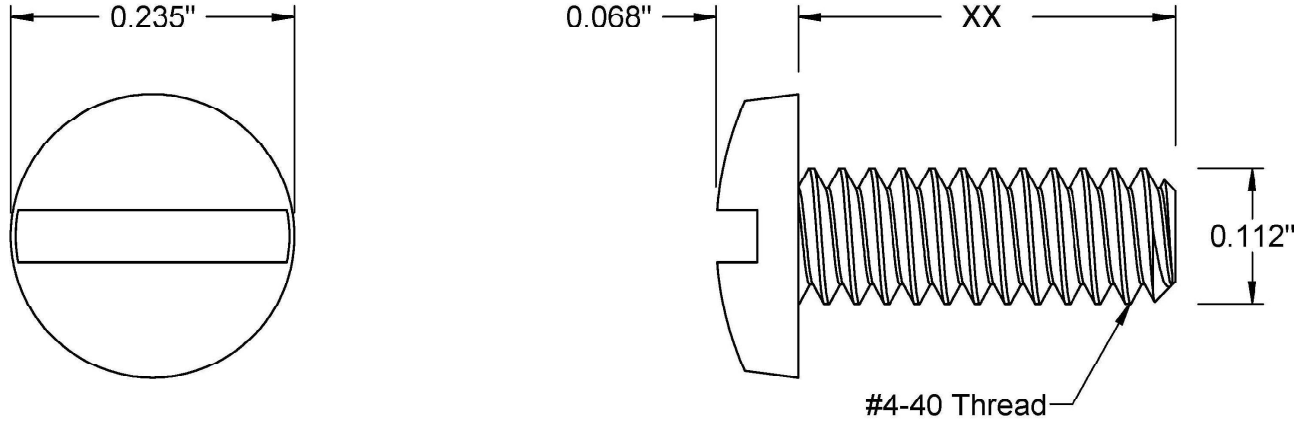

This drawing and the information contained herein are the confidential and proprietary property of Global Supply LLC

PART NUMBER	LENGTH
4C6MIBN	3/32
4C8MIBN	1/8
4C9MIBN	9/64
4C12MIBN	3/16
4C16MIBN	1/4
4C18MIBN	9/32
4C20MIBN	5/16
4C24MIBN	3/8
4C28MIBN	7/16
4C32MIBN	1/2
4C36MIBN	9/16
4C40MIBN	5/8
4C44MIBN	11/16



NOTES:
 1. INTERPRET DRAWINGS PER ASME Y14.5M-1994 STANDARD
 2. DIMENSIONS & TOLERANCES PER ANSI/ASME B18.6.3
 3. ROHS AND REACH COMPLIANT

DRAWING SCALE: STANDARD		MATERIAL: NYLON	DESCRIPTION: #4-40 SLOTTED BINDING HEAD MACHINE SCREW
TOLERANCES: <i>Unless specified otherwise, all dimensions are in inches</i>	x.xxx +/- 0.005 x.xx +/- 0.010 x.x +/- 0.010	FINISH: PLAIN	PART NUMBER: 4CXXMIBN
DRAWN BY: L.CLARY	FSCM No. 67012		 Global Supply LLC WORLDWIDE SUPPLIER OF ELECTRONIC HARDWARE, FASTENERS & COMPONENTS <small>500 Division Street, Campbell, CA 95008-6906 Tel: 408 960 0370 Fax: 408 960 0375 Web: www.globalsupply.com</small>
REV:	APPROVAL	DATE:	
INITIAL RELEASE	LJA	Mar 6, 2018	
		ECCN EAR99 = NLR (No License Required)	