

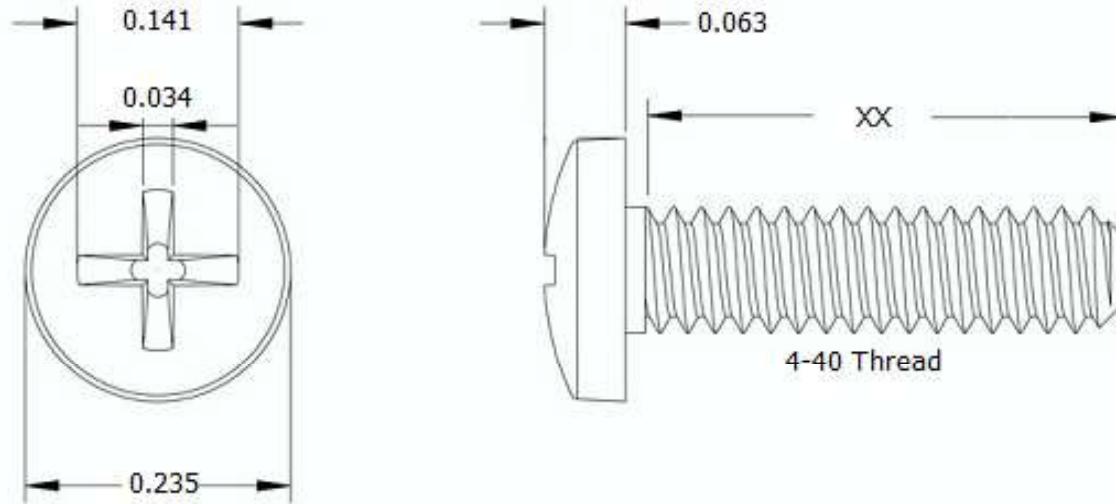

This drawing and the information contained herein are the confidential and proprietary property of Global Supply LLC



PART NUMBER	LENGTH
4C8MPBSP	1/8
4C12MPBSP	3/16
4C16MPBSP	1/4
4C20MPBSP	5/16
4C24MPBSP	3/8
4C28MPBSP	7/16
4C32MPBSP	1/2
4C36MPBSP	9/16
4C40MPBSP	5/8
4C44MPBSP	11/16
4C48MPBSP	3/4
4C56MPBSP	7/8
4C64MPBSP	1

NOTES:  
 1. INTERPRET DRAWINGS PER ASME Y14.5M-1994 STANDARD.  
 2. DIMENSIONS & TOLERANCES PER ANSI/ASME B18.6.3.  
 3. ROHS AND REACH COMPLIANT

<b>DRAWING SCALE:</b>		<b>MATERIAL:</b>		<b>DESCRIPTION:</b>	
<b>STANDARD</b>		<b>STAINLESS STEEL</b>		<b>4-40 PHILLIPS BINDER HEAD MACHINE SCREW</b>	
<b>TOLERANCES:</b> <i>Unless specified otherwise, all dimensions are in inches</i>		<b>FINISH:</b>		<b>PART NUMBER:</b>	
x.xxx +/- 0.005 x.xx +/- 0.010 x.x +/- 0.010		<b>PASSIVATE</b>		<b>4CXXMPBSP</b>	
<b>DRAWN BY:</b>	L CLARY		<b>FSCM No.</b>		 <b>Global Supply LLC</b> WORLDWIDE SUPPLIER OF ELECTRONIC HARDWARE, FASTENERS & COMPONENTS <small>500 Division Street, Campbell, CA 95008-6906          Tel: 408 960 0370 Fax: 408 960 0375 Web: www.globalsupply.com</small>
<b>REV:</b>	<b>APPROVAL</b>	<b>DATE:</b>	<b>67012</b>		
<b>INITIAL RELEASE</b>	LJA	<b>Jul 9, 2018</b>	<b>ECCN</b>		
			<b>EAR99 = NLR (No License Required)</b>		