

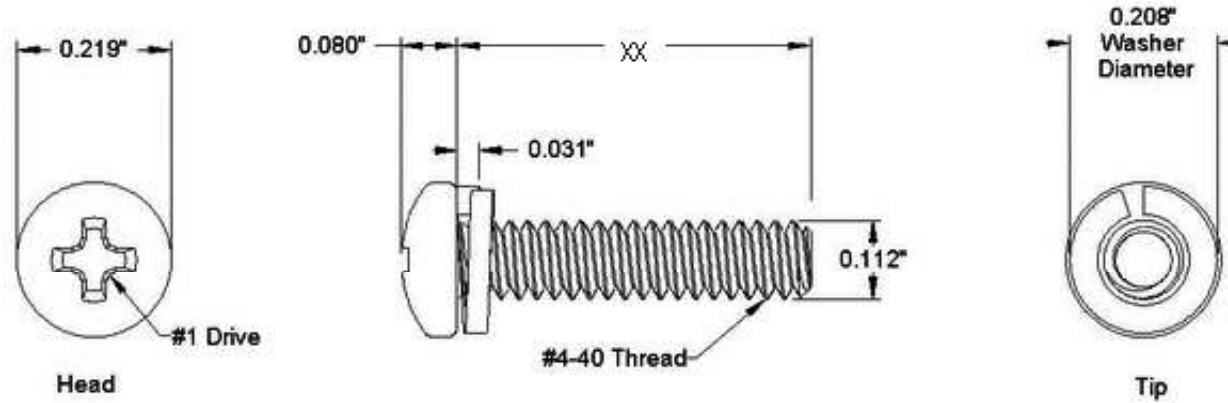

This drawing and the information contained herein are the confidential and proprietary property of Global Supply LLC



PART NUMBER	LENGTH
4C8MPP3P/SLK	1/8
4C12MPP3P/SLK	3/16
4C16MPP3P/SLK	1/4
4C20MPP3P/SLK	5/16
4C24MPP3P/SLK	3/8
4C28MPP3P/SLK	7/16
4C32MPP3P/SLK	1/2
4C40MPP3P/SLK	5/8
4C48MPP3P/SLK	3/4
4C56MPP3P/SLK	7/8
4C64MPP3P/SLK	1

NOTES:
 1. INTERPRET DRAWINGS PER ASME Y14.5M-1994 STANDARD
 2. DIMENSIONS & TOLERANCES PER ANSI/ASME B18.13
 3. ROHS AND REACH COMPLIANT

DRAWING SCALE:		MATERIAL:	DESCRIPTION:
STANDARD		316 STAINLESS STEEL	#4-40 PAN HEAD PHILLIPS MACHINE SCREWS, SPLIT LOCK SEMS
TOLERANCES: <i>Unless specified otherwise, all dimensions are in inches</i>	x.xxx +/- 0.005 x.xx +/- 0.010 x.x +/- 0.010	FINISH:	PART NUMBER:
		PASSIVATE	4CXXMPP3P/SLK
DRAWN BY:	L.CLARY	FSCM No.	 Global Supply LLC WORLDWIDE SUPPLIER OF ELECTRONIC HARDWARE, FASTENERS & COMPONENTS <small>500 Division Street, Campbell, CA 95008-6906 Tel: 408 960 0370 Fax: 408 960 0375 Web: www.globalsupply.com</small>
REV:	APPROVAL	DATE:	
INITIAL RELEASE	LJA	Feb 9, 2009	
A	LJA	Aug 26, 2014	
B	LJA	Apr 19, 2018	
		ECCN	
		EAR99 = NLR (No License Required)	