

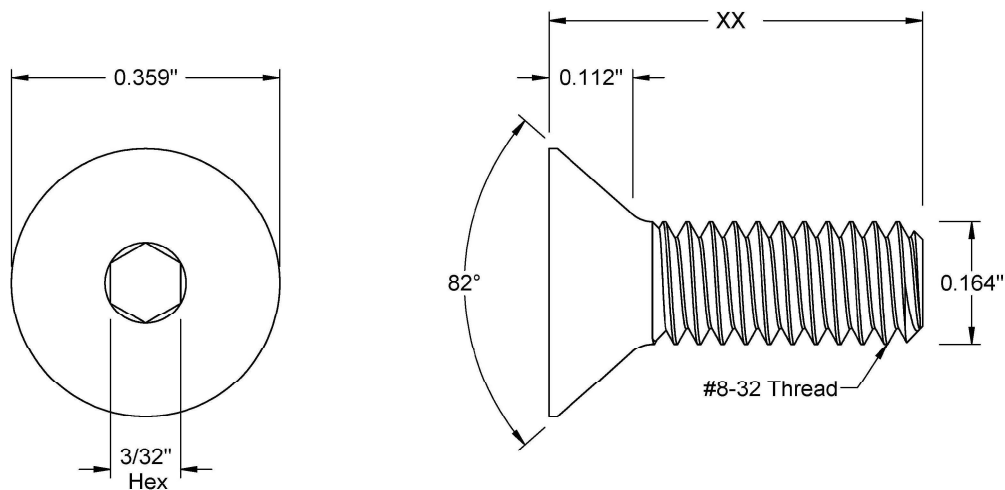

This drawing and the information contained herein are the confidential and proprietary property of Global Supply LLC



PART NUMBER	LENGTH
8C8SFCSS	1/8
8C12SFCSS	3/16
8C16SFCSS	1/4
8C20SFCSS	5/16
8C24SFCSS	3/8
8C28SFCSS	7/16
8C32SFCSS	1/2
8C40SFCSS	5/8
8C48SFCSS	3/4
8C56SFCSS	7/8
8C64SFCSS	1

NOTES:
 1. INTERPRET DRAWINGS PER ASME Y14.5M-1994 STANDARD.
 2. DIMENSIONS & TOLERANCES PER ANSI/ASME B18.3
 3. ROHS AND REACH COMPLIANT

DRAWING SCALE:		MATERIAL:	DESCRIPTION:
STANDARD		STAINLESS STEEL	#8-32 SOCKET FLAT HEAD MACHINE SCREW
TOLERANCES: <i>Unless specified otherwise, all dimensions are in inches</i>	x.xxx +/- 0.005 x.xx +/- 0.010 x.x +/- 0.010	FINISH:	PART NUMBER:
		SILVER	8CXXSFCSS
DRAWN BY:	L.CLARY		 Global Supply LLC WORLDWIDE SUPPLIER OF ELECTRONIC HARDWARE, FASTENERS & COMPONENTS <small>500 Division Street, Campbell, CA 95008-6906 Tel: 408 960 0370 Fax: 408 960 0375 Web: www.globalsupply.com</small>
REV:	APPROVAL	DATE:	
INITIAL RELEASE	LJA	May 16, 2018	
		FSCM No. 67012	
		ECCN	
		EAR99 = NLR (No License Required)	